

## NOTE

### The Effect of Surfactant Monolayers on the Heat Transfer Through Air/Water and Oil/Water Interfaces Using IR Imaging Technique

**An experimental investigation on the effect of surfactant monolayers on the heat transfer through air/water and oil/water interfaces was carried out by observing the changes of surface temperature with IR Imaging Radiometer (Model 760). The heat transfer resistance of various single component and mixed monolayers at air/water and oil/water systems was studied. The results show that the surfactant monolayers introduce a noticeable heat transfer resistance to the heat transfer process across the interface. The solid monolayers exhibit lower resistance to heat transfer than the liquid monolayers at the oil/water interface. At air/water interface, the presence of monolayer decreases the evaporative cooling process and therefore increases the surface temperature rapidly. However, the presence of a monolayer at oil/water interface increases the heat transfer resistance across the oil/water interface. Heat transfer resistance increases as the chain length of fatty acid increases at the oil/water interface. The effects of phase-transition from a two-dimensional solid to the liquid state in cholesterol-arachidyl mixed monolayers was observed from the change in heat transfer resistance of the monolayers at the oil/water interface. The optimum molecular packing at the 1:3 molecular ratio in mixed surfactant monolayers of oleic acid–cholesterol and stearic acid–stearyl alcohol at the oil/water interface was also observed by this technique.** © 1998 Academic Press

**Key Words:** thin liquid films; single component and mixed monolayers; heat transfer resistance; phase transition in monolayers; molecular packing; 1:3 molar ratio effect; evaporative cooling effect; effect of the chain length of fatty acids; on heat transfer resistance.

#### INTRODUCTION

The role of surface active agents in heat transfer process has attracted the attention of many researchers for years (1). The studies indicated that the surfactant can decrease the violent evaporation process of a liquid by covering the surface (2). Langmuir and Langmuir (3) investigated the mechanism of this phenomenon in the evaporation of aqueous ether solutions with or without a monolayer present. Also several researchers have carried out the theoretical modeling of the effects of surface active agents on the convection of thin liquid films (4–7). However, these studies focused on the effect of surfactant on the liquid film's hydrodynamic stability. There has not been a systematic experimental study to elucidate the molecular mechanism of the heat transfer through the air/liquid or liquid/liquid interface in the presence of monolayers. The purpose of the current research is to determine how single component monolayers and mixed monolayers affect the heat transfer process through the interface using IR Imaging Radiometer (Model 760) which can give an accurate real-time analysis of static or dynamic thermal patterns and temperature changes.

#### MATERIALS

Cholesterol (purity 99+%) was purchased from Sigma Chemical Co. Arachidyl alcohol (98%), oleic acid (purified), 1-octadecanol (95%), chloroform, methanol, *n*-hexane, and hexadecane were obtained from Fisher Scientific. Myristic acid and palmitic acid were supplied by J. T. Baker Chemical Co. Stearic acid was purchased from Matheson Coleman & Bell Co. All the chemicals and solvents used were of high purity grade and were used without any further purification. The cholesterol concentration was 1 mg/ml in the mixed solvent system of chloroform + methanol + *n*-hexane (1:1:3, v/v/v), which has been used as spreading solvent to form monolayers. Equimolar solutions of oleic acid and arachidyl alcohol, like that of cholesterol in the same solvent mixture, were prepared to form monolayers. The close-packed monolayer was formed as follows: The surfactant solution was deposited as small drops at various points on the water surface through a micrometer syringe until there was no spreading movement of the drop and an additional drop of solution remained unspread on the surface. The solvents in the monolayers were given 15 minutes to evaporate. Hexadecane was then gently added on top of the water to form the oil/water system. Twice-distilled water was used throughout the entire study.

#### METHODS

The experimental design is shown in Fig. 1. The heat transfer resistance was measured as the time required for the surface temperature of water or hexadecane (oil) to increase by 1°C when the liquid was heated from below. By using the same Petri dish, same liquids (water and/or hexadecane), a constant liquid depth, a constant heat flux from the heater to the liquid, and constant surface temperature of the heater in each experiment, we can see and confirm that the monolayer at the interface has indeed had a significant influence on the heat transfer through the interface. A stopwatch was used to record the time required for 1°C increase in surface temperature for each experiment. We covered the working area with a Plexiglas box to avoid air convection. The heater had the same size as that of the Petri dish, which had a flat bottom to ensure a vertical heat transfer process. Before each measurement, we allowed the heater surface (point *P* in Fig. 1) to equilibrate for a couple of hours such that the surface temperature reached to a maximum value (30°C measured by IR, Imaging Radiometer). Then we put the Petri dish on the heater and recorded the time for the temperature of water or oil surface to increase 1°C. The depth of water and hexadecane were 3 and 3.9 mm, respectively. The experimental apparatus is shown in Fig. 2. All the experiments were carried out at room temperature  $24 \pm 1^\circ\text{C}$ . Each point was repeated several times, and the average time value and standard deviations were determined and plotted as error bars in Fig. 3–7. The standard deviation was less than 4% of the measured time value of each point in the graphs.

One important issue that must be pointed out here is the interfacial instability of thin liquid films when heated from below (8). When liquid at the bottom of the Petri dish is heated, the liquid has a tendency to rise. Because interfacial tension decreases with increasing temperature, the rising liquid produces a local lowering of interfacial tension and hence an outward directed lateral force along the interface. As a result, the initially stagnant film becomes unstable and develops interfacial convection. Let us consider that the oil/water system is a composite system (9). Heat transfer through three regions (i.e., water, surfactant monolayer, and oil) should be considered. There may be convection occurring in water or oil, but an insoluble monolayer can be

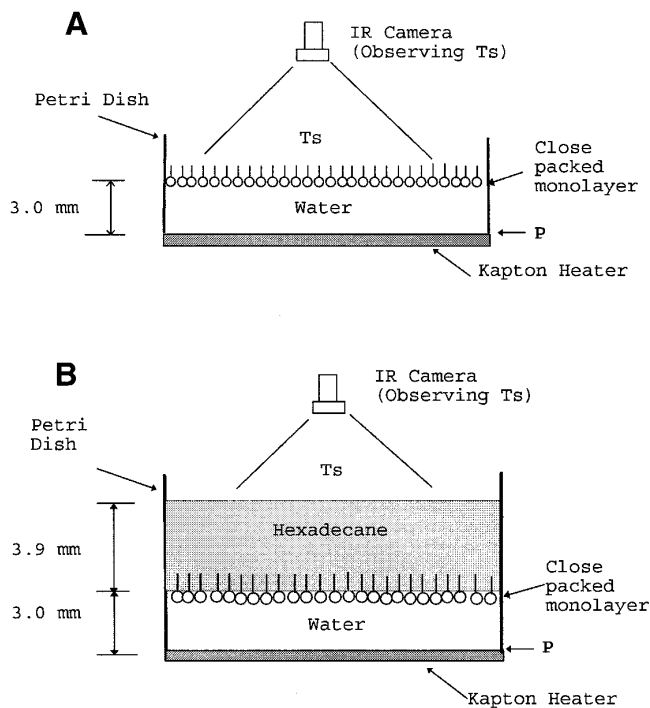

FIG. 1. Experimental design for the study of the heat transfer resistance of monolayer across the interface. (A) air/water interface; (B) oil/water interface.

considered as a solid slab and the heat conducts only through the monolayer. Therefore it is very important to keep the temperature gradient ( $5^{\circ}\text{C}$  in our study) across the liquid films as low as possible in order to minimize the disturbance of the convection in the liquid films. Also the experimental conditions must be constant in each measurement so that the comparison of the differences of heat transfer resistance through different monolayers is meaningful.

The infrared radiometer used in this study was an Inframetrics Model 760. The instrument combines superior image quality and thermal sensitivity with true temperature measurement display. The typical noise equivalent temperature difference is less than  $0.05^{\circ}\text{C}$ . The temperature measurement accuracy is  $\pm 2^{\circ}\text{C}$  or  $\pm 2\%$ . The temperature measurement range is  $-20 \sim +400^{\circ}\text{C}$ . The typical minimum detectable temperature is  $0.1^{\circ}\text{C}$  (at  $30^{\circ}\text{C}$ ). It should be emphasized that this sensitivity applies only to temperature changes or relative temperatures and does not imply a comparable accuracy in measuring absolute temperatures. Because we are interested only in the temperature changes, this instrument satisfies our experimental requirements. The heater used was Kapton Heater Kit (Cole-Parmer Instrument Co.). And the power supply was a FisherBiotech FB150.

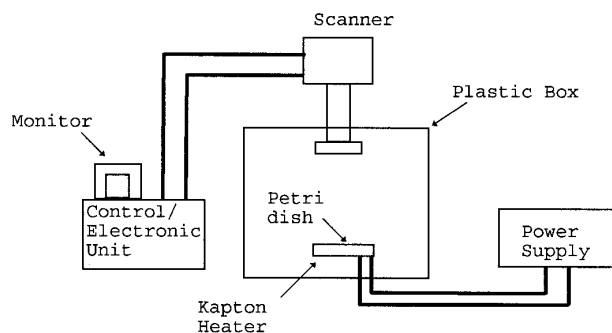

FIG. 2. A sketch of the experimental setup for the study of the heat transfer resistance of monolayer.

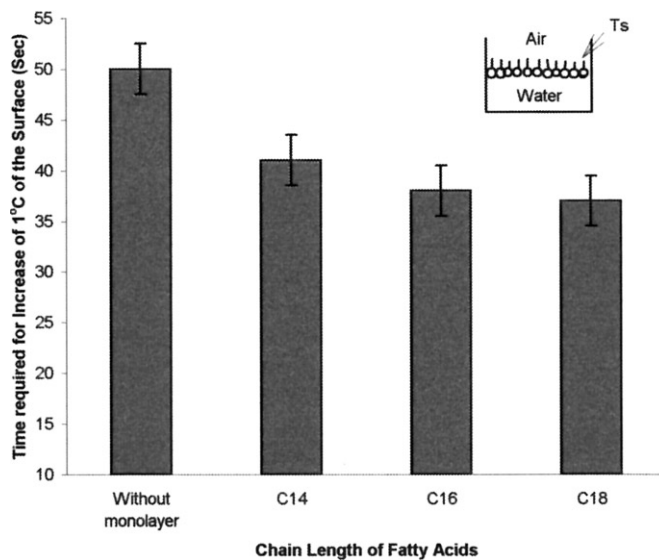

FIG. 3. The time required for the surface temperature of water with or without monolayers at the air/water interface to increase by  $1^{\circ}\text{C}$  as a function of fatty acid chain length.

## RESULTS AND DISCUSSION

### *The Effect of Chain Length of Surfactant Molecules on the Interfacial Heat Transfer*

Figures 3 and 4 show the time for the surface temperature of water or hexadecane (oil) to increase by  $1^{\circ}\text{C}$  (heat transfer resistance) against the chain length of various fatty acid monolayers. At the air/water interface (Fig. 3), the presence of a monolayer decreases the time required for  $1^{\circ}\text{C}$  rise of surface temperature. The results may be explained by the evaporative cooling effect at the interface. Without monolayer at the air/water interface, evaporative cooling lowers the water surface temperature. Therefore the rate of the heat accumulation at the interface is slow, and the time needed for the surface temperature to increase is longer. With a monolayer at the interface, the effect of evaporative cooling is significantly reduced; thus, the heat accumulates faster at the interface and causes a shorter time for the temperature of the air/water interface to increase by  $1^{\circ}\text{C}$ . Jarvis *et al.* (10) have shown that under suitable experimental conditions a monolayer can increase the surface temperature as much as 6 or  $7^{\circ}\text{C}$  as compared to the surface temperature without a monolayer present.

At the oil/water interface, however, the presence of a monolayer increases the heat transfer resistance across the oil/water interface (Fig. 4). The time required for  $1^{\circ}\text{C}$  rise of surface temperature increases as the chain length of fatty acid monolayer increases. It is obvious that there is no evaporative cooling effect associated with the oil/water interface. The presence of a monolayer at the interface is like putting an extra slab of molecular dimension into the heat transfer process. Therefore the time required for  $1^{\circ}\text{C}$  rise of surface temperature is longer than that of the system without a monolayer. It is interesting to note that the oil/water system is sensitive to a change of two carbon atoms ( $\approx 3 \text{ \AA}$ ) in the thickness of a monolayer for the heat transfer process across the oil/water interface.

### *The Effect of Mixed Monolayers on Interfacial Heat Transfer Process*

Figures 5–7 show the time required for  $1^{\circ}\text{C}$  rise of surface temperature against the mole fraction of the components in various mixed monolayers present at the air/water and oil/water interfaces. As we can see, the effect of the mixed monolayers at the oil/water interface on the heat transfer across the interface is more distinct as compared to the effects at the air/water interface. This can be explained as follows. We studied the oil/water interface by

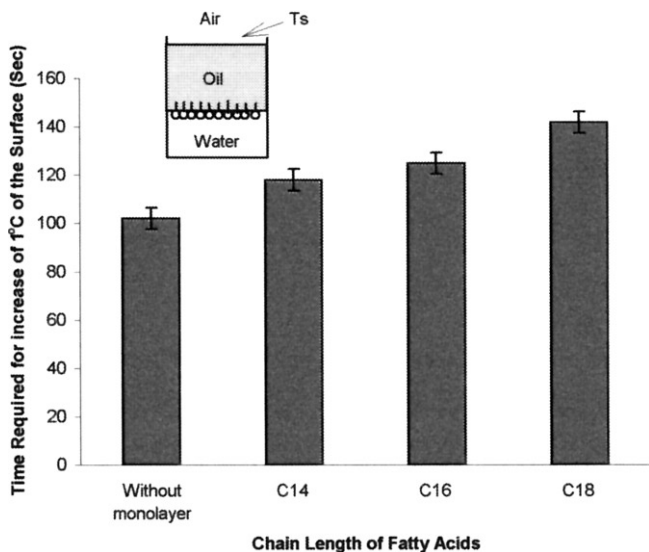

FIG. 4. The time required for surface temperature of oil with or without monolayers at the oil/water interface to increase by 1°C as a function of fatty acid chain length (oil/water = hexadecane/water).

monitoring the change of the surface temperature of the oil by 1°C. The oil layer in fact amplifies any effect of a monolayer at the interface. It gives us an amplified view of the effect of a monolayer on heat transfer across the interface. In contrast, the IR Radiometer directly monitors air/water interface, and the effect of the monolayer on the temperature change at the air/water interface was too small to be detected by the IR. Therefore, the following discussions are based on the results of the oil/water system.

Figure 5 shows the time required for 1°C rise of oil surface temperature with an arachidyl alcohol-cholesterol monolayer at the oil/water interface against

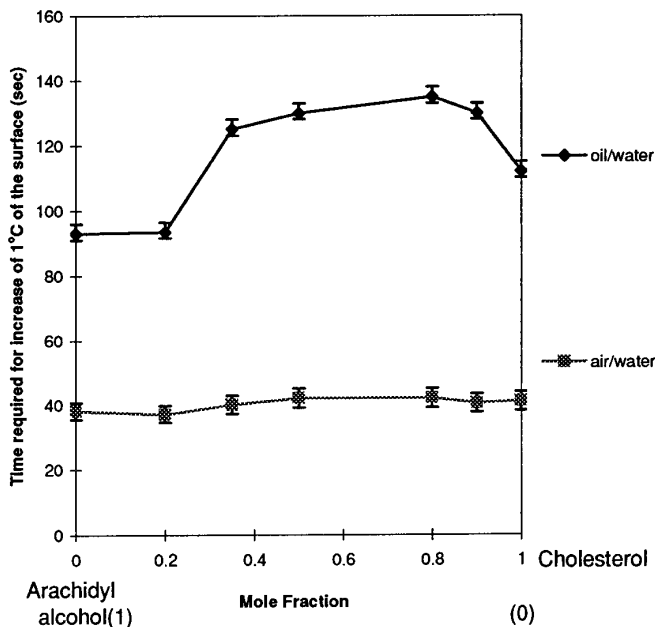

FIG. 5. The time required for the surface temperature of water or oil with arachidyl alcohol-cholesterol monolayer at air/water or oil/water interfaces to increase by 1°C as a function of mole fraction of the mixed monolayer (oil/water = hexadecane/water).

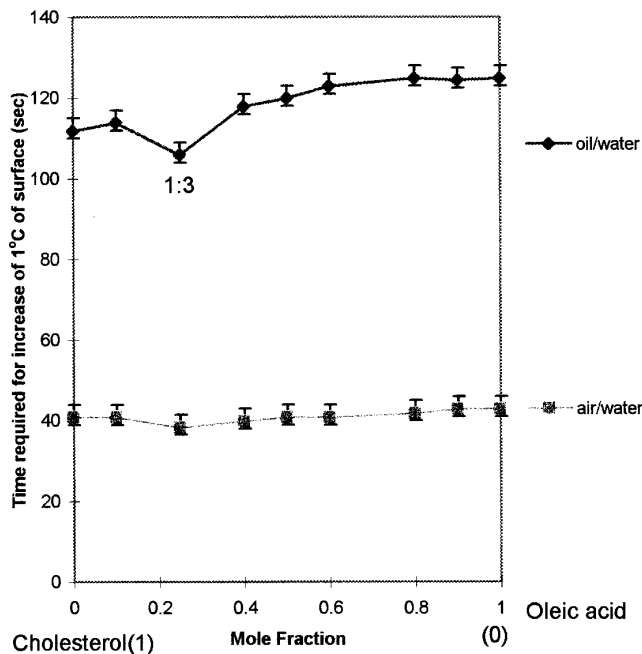
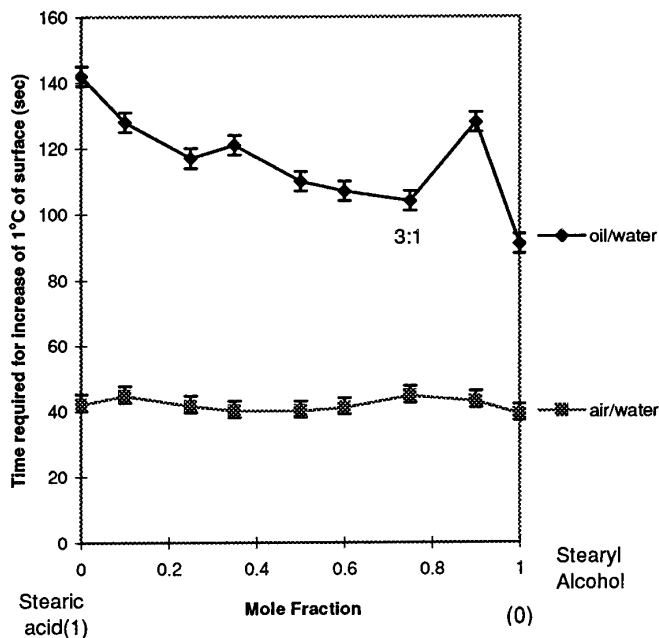

FIG. 6. The time required for surface temperature of water or oil with oleic acid-cholesterol monolayers at air/water or oil/water interfaces to increase by 1°C as a function of mole fraction of the mixed monolayer (oil/water = hexadecane/water).

the mole fraction of the mixture. As the mole ratio of arachidyl alcohol-cholesterol reaches 80:20, the time required for 1°C rise of surface temperature has a striking increase. This result is consistent with the results of the phase transition in mixed monolayer using retardation of evaporation of water (11). It has been shown that arachidyl alcohol monolayer is in a two-dimensional solid state, whereas the cholesterol monolayer is in a two-dimensional liquid state (12). Because of the strong interactions between molecules in a solid monolayer, heat conduction is faster than that through a liquid monolayer. By mixing more than 20 mol% of cholesterol into the arachidyl alcohol, the solid state monolayer can be fluidized, and the fluidization can be detected by the increase of the time required for 1°C rise of the oil surface temperature with the monolayer at the oil/water interface.

Figure 6 shows the time required for 1°C rise of oil surface temperature with an oleic acid-cholesterol monolayer at the oil/water interface against the mole fraction of the mixture. We observed the shortest time required for 1°C rise of oil surface temperature with the mixed monolayer at the oil/water interface at 1:3 mole ratio of oleic acid and cholesterol. The time required for 1°C rise of oil surface temperature with oleic acid monolayer at the oil/water interface is longer than that with cholesterol monolayer, although oleic acid forms highly expanded liquid monolayers (13). This may be the result of the fact that cholesterol molecules have a smaller height and an asymmetric structure, which forms a more rigid monolayer than oleic acid. It indicates that the tightest molecular packing (or the maximum lateral interaction in the hydrocarbon portion of the monolayers) occurs at the 1:3 molar ratio in the oleic acid-cholesterol monolayer.

Figure 7 shows the time required for 1°C rise of oil surface temperature with a stearyl alcohol-stearic acid monolayer at the oil/water interface against the mole fraction of the mixture. It is interesting to see that the time required for 1°C rise of surface temperature at the 1:3 molar ratio of stearic acid and stearyl alcohol is minimum. This indicates that at this molar ratio, the stearic acid and stearyl alcohol monolayer has the maximum monolayer molecular packing formation (i.e., hexagonal geometrical arrangement of surfactant molecules in mixed monolayer) (14, 15). Also the time required for 1°C rise of surface temperature with the stearic acid monolayer at the oil/water interface is longer than that with the stearyl alcohol monolayer despite having the same alkane



**FIG. 7.** The time required for the surface temperature of water or oil with stearyl alcohol–stearic acid monolayer at air/water or oil/water interfaces to increase by 1°C as a function of mole fraction of the mixed monolayer (oil/water = hexadecane/water).

chain. This may be caused by stearyl alcohol molecules forming more close-packed solid monolayers while stearic acid molecules form fluid monolayers.

In summary, the present study showed that the presence of a surfactant monolayer has a significant effect on the heat transfer process across the air/water or oil/water interface. The phase transition in mixed monolayers can be detected by measuring the time required for 1°C rise of surface temperature with the monolayer at the oil/water interface using IR imaging method. It is very interesting to note that a change of two carbons ( $\approx 3 \text{ \AA}$ ) in fatty acid causes a dramatic change in the heat transfer process across the oil/water interface. These results have significant implications for heat transfer across liquid/liquid interface in distillation of mixtures of immiscible liquids.

## REFERENCES

1. Berg, J. C., and Boudart, M., *J. Fluid Mech.* **24**, 721 (1966).
2. Dauzere, C., *C. R. Acad. Sci., Paris* **155**, 394 (1912).
3. Langmuir, I., and Langmuir, D. B., *J. Phys. Chem.* **31**, 1719 (1927).
4. Pearson, J. R. A., *J. Fluid Mech.* **4**, 489 (1958).
5. Berg, J. C., and Acrivos, A., *Chem. Eng. Sci.* **20**, 737 (1965).
6. Palmer, H. J., and Berg, J. C., *J. Fluid Mech.* **47**, 779 (1971).
7. Palmer, H. J., and Berg, J. C., *J. Fluid Mech.* **51**, 385 (1972).
8. Miller, C. A., and Neogi, P., "Interfacial Phenomena," surfactant science series vol. 17. Marcel Dekker, New York, 1985.
9. Fahien, R. W., "Fundamentals of Transport Phenomena." McGraw-Hill, New York, 1983.
10. Jarvis, N. L., Timmons, C. O., and Zisman, W. A., The Effect of Monomolecular Films on Surface Temperature, 1960. [presented at Symposium on Transport Processes through Monolayers, before the Colloid Division, 138<sup>th</sup> meeting of the American Chemical Society, New York City, September 1960]
11. Rao, Y. K., and Shah, O. D., *J. Colloid Interface Sci.* **137**, 25 (1990).
12. Shah, D. O., and Schulman, J. H., *J. Lipid Res.* **8**, 215 (1967).
13. Shah, D. O., "Advances in Lipid Research" (R. Paolitti and D. Kritchevsky, Eds.), p. 347. Academic Press, New York, 1970.
14. Shah, D. O., *J. Colloid Interface Sci.* **37**, 744 (1971).
15. Shah, D. O., "Micells, Microemulsions, and Monolayers Science and Technology," Marcel Dekker Inc., New York, 1998.

H. Fang  
D. O. Shah<sup>1</sup>

Center for Surface Science & Engineering  
Departments of Chemical Engineering and Anesthesiology  
University of Florida  
Gainesville, Florida 32611

Received February 11, 1998; accepted April 20, 1998

<sup>1</sup> To whom correspondence should be addressed.